

DATA SHEET

CLT CEILING SOLUTION

The panel offers elegant solution to install over CLT surfaces while improving the acoustics of the space. Designed for a fast and easy install.

COMPOSITE FIRE RATING

Expected Class B (per ASTM E-84)
Awaiting final lab results.

ACOUSTIC PERFORMANCE

Initial models indicate an NRC of 0.6.
Awaiting final lab results.

COMPOSITION

The core is 1-1/2" fire rated MDF with a paper backed veneer. The finish coat is a waterborne clear coat.

SIZING

Typical planks are 4" wide x 2', 3', 4', 5', 6', 8' in length. The installer can choose the lengths for randomization to achieve a look similar to CLT.

TOLERANCE

(+/- 1/16")

CUSTOMIZATION

The ends of the planks can be doweled or biscuit-ed for field alignment. This is an up charge.

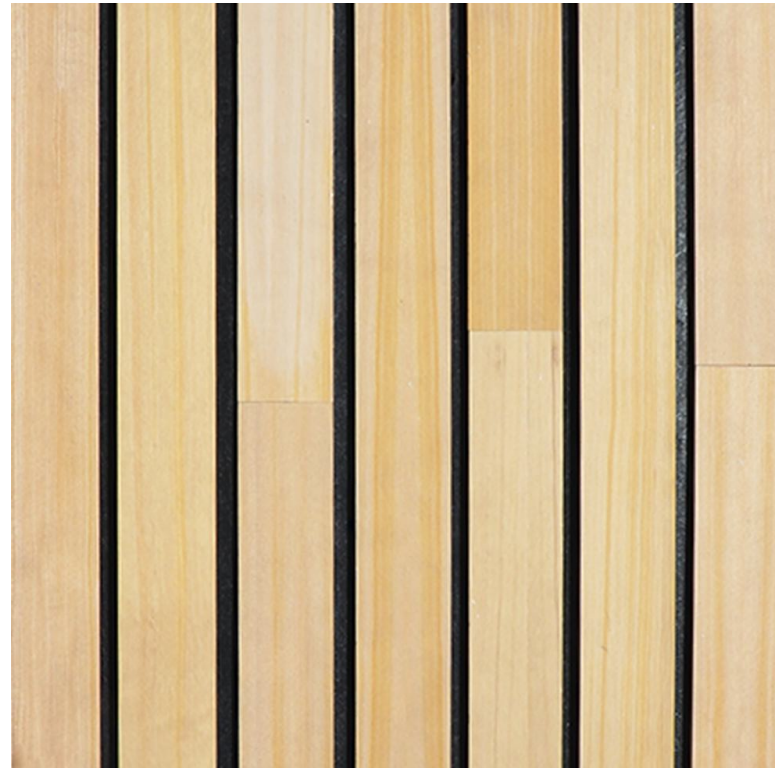

KEY SELECTION ATTRIBUTES

- Complete standard system from one manufacturer, including panels, suspension, clips, and trim options.
- Custom options include unique panel configurations and lengths and additional species and finishes.
- The natural warmth of wood can contribute to biophilic designs and building certification standards
- Standard veneers feature various species and cuts for beautiful wood visuals.

TYPICAL APPLICATIONS

- Auditoriums & Assembly Halls
- Museums & Exhibits
- Office Environments
- Recording Studios
- Restaurants
- Museums & Exhibits

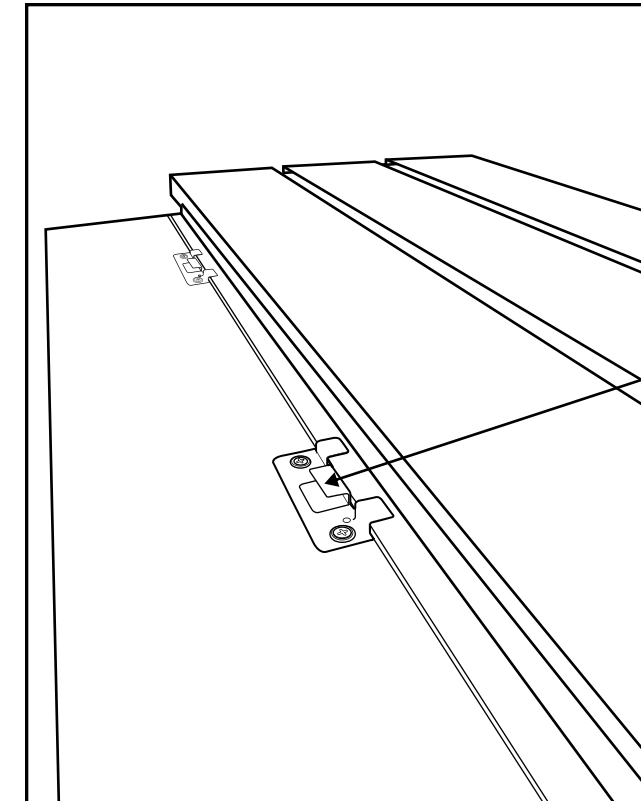

INSTALLATION

An steel cleat system is available for ceiling mounting. The cleats are to be mounted every 16". If desired

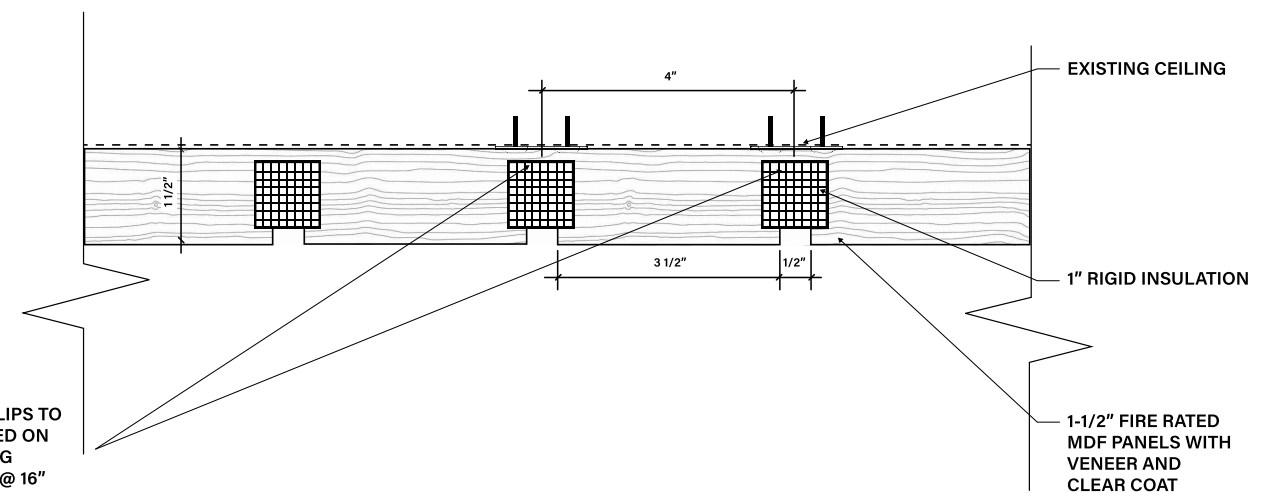

CUSTOM CLIPS TO BE SCREWED ON THE CEILING BLOCKING @ 16" O.C. CLIPS WILL BE INCLUDED WITH ORDER

EXISTING CEILING
1" RIGID INSULATION
1-1/2" FIRE RATED MDF PANELS WITH VENEER AND CLEAR COAT